

Left elevation

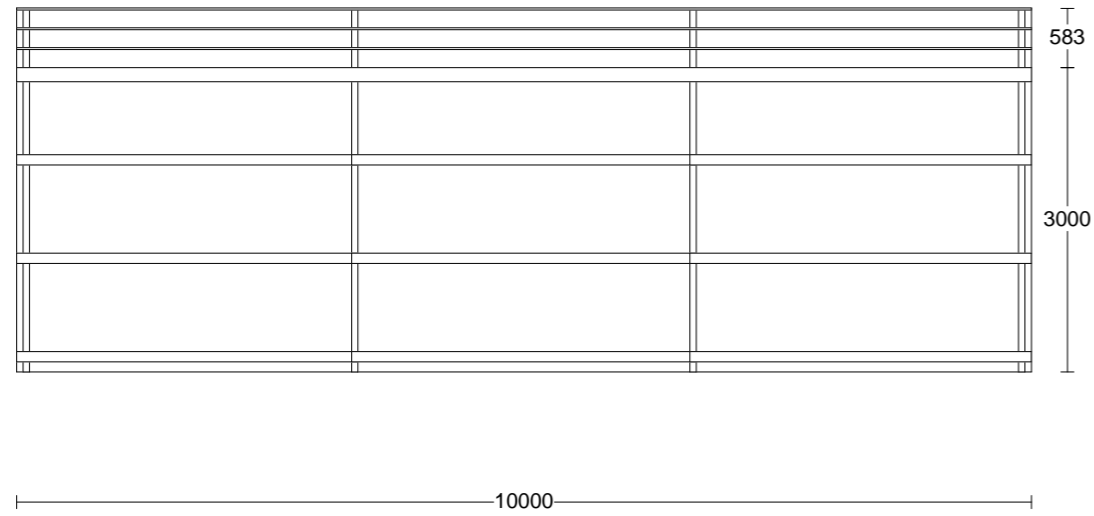

Right elevation

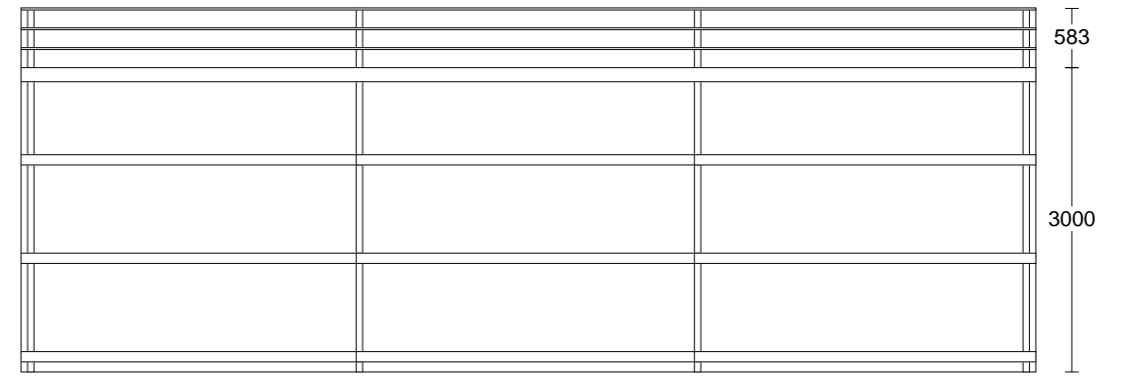

Front elevation

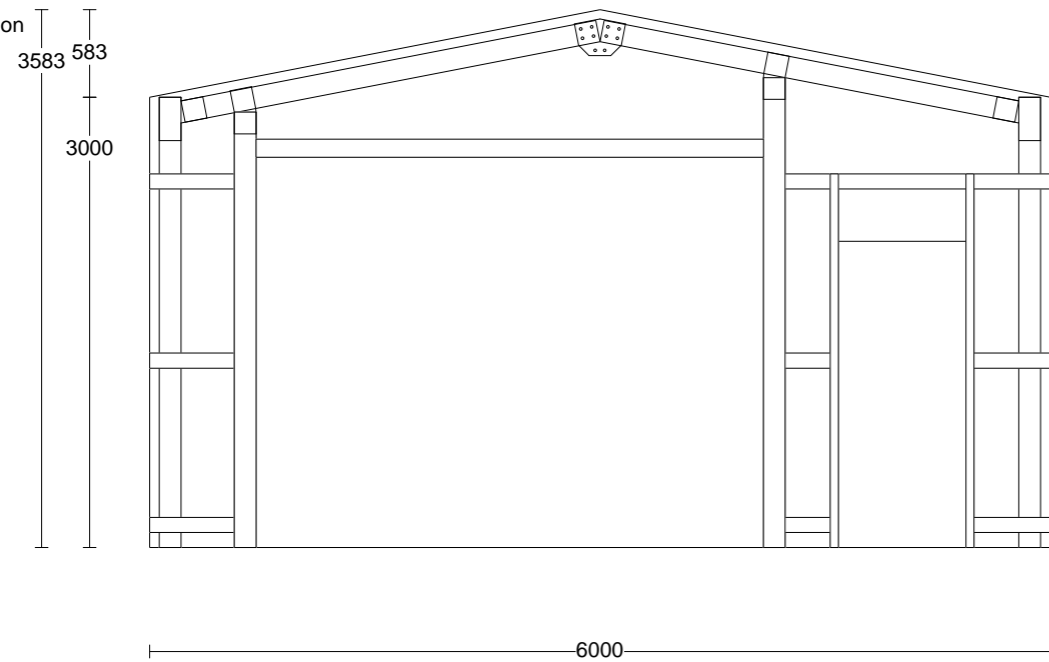

Rear elevation

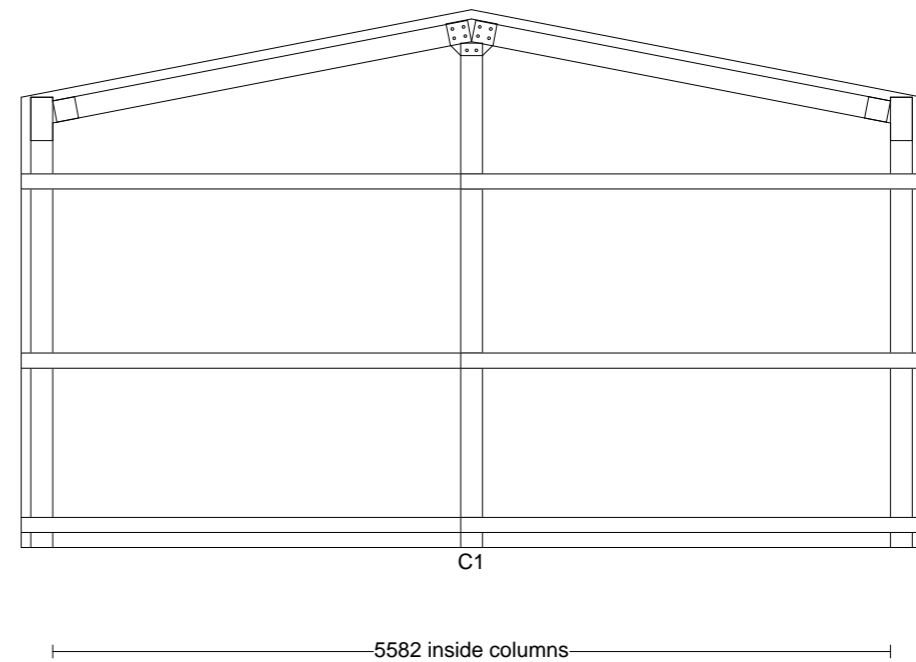

Plan overview: not to scale

	Property:	Prepared by:	Drawing/Job no:	Date:	Girt depth:	Drawn by:	Checked by:	Snow load	Wind load	Terrain type	Soil safe bearing capacity	Sheet no:	Structural engineer:	Signature:
	Mr Hutchinson	Garage Quotes Unit 1, Ednaston Home Farm Ashbourne Contact: Simon Moore 08003168789	GQAB_JMO132155	14/Dec/2009 13:22	64				0.4 kN/sq m	Basic wind speed (Vb): 24m/s	Country	100 kPa	2 of 10	Bernard Kanya Kanya Consulting Ltd 52c Church Street Inverness IV1-1EH 01463 230666

BRACING Level 1: bracing strap/tensioners (per roll) 32 * 1.2 diagonally. in two end bays per side, and end bays on roof.

The design and detail on these drawings are applicable to this project only and may not be reproduced in whole or any part or used for other purposes without the written permission of TwinSpan© Ltd with whom copyright resides.

Note: sheeting omitted for clarity. See sheet no 10 for sheeting details

This document was created with Win2PDF available at <http://www.win2pdf.com>.
The unregistered version of Win2PDF is for evaluation or non-commercial use only.
This page will not be added after purchasing Win2PDF.